

Sri Lanka Law College Entrance Examination - Model Paper

(02) General Knowledge and Intelligence
 Part I - General Knowledge

One hour

Instructions to Candidates

Very Important :

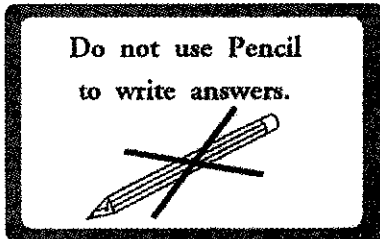

* Answerscripts where the numbers are not written as indicated below will not be marked / evaluated.

1 2 3 4

Write your Index Number here and on page 3 in the space indicated.

.....

Checked as correct

.....

Invigilator's Initials

Important :

- * This paper consists of 50 questions on 05 pages.
- * Before answering the paper arrange all the pages in order.
- * Answer all questions on this paper itself.
- * The time allowed for this paper is one hour.
- * Commence answering only after the Centre Supervisor's announcement.
- * Instructions given should be strictly followed in answering this paper and marks will not be awarded for answers not in accordance with these instructions.
- * Even if you are not attempting the paper hand it over to the Supervisor.
- * Write the answers clearly and legibly in blue or black ink only and not in pencil.
- * It is an offence to remove this paper from the examination hall or turn out photocopies of the same.
- * Answer scripts with illegible figures, illegible handwriting, those where erasing fluid has been used and written in pencil will not be marked / evaluated.

For Examiner's use only

Page No.	Question Nos.	Marks awarded
2	1 - 14	
3	15 - 27	
4	28 - 39	
5	40 - 50	
Total		

Final Score

In figures	
In words	
Marking Examiner	
Checked by	

● For each of the questions from No. 1 to 30, select the correct or the most appropriate answer and write the number relevant to it on the dotted line provided against the question.

1. A Justice of the Peace is appointed by
(1) the President. (2) the Minister of Justice.
(3) the Judicial Commission. (4) the Attorney General. (.....)
2. In which year was the Central Bank of Sri Lanka established?
(1) 1948 (2) 1949 (3) 1950 (4) 1951 (.....)
3. What is the emergency number to which you can report on matters regarding bribery and corruption?
(1) 1919 (2) 1929 (3) 1954 (4) 1956 (.....)
4. Who was the last Governor and the first Governor General of Sri Lanka?
(1) Sir Henry Monck-Mason Moore (2) Sir Oliver Goonetilleke
(3) Lord Soulbury (4) Mr. William Gopallawa (.....)
5. Which was made the 25th administrative district in Sri Lanka, according to the 7th amendment of the Constitution of the Democratic Socialist Republic of Sri Lanka?
(1) Mullaitivu (2) Kilinochchi (3) Ampara (4) Mannar (.....)
6. Which province in Sri Lanka has the largest number of inland reservoirs?
(1) Northern (2) North Central (3) North Western (4) Eastern (.....)
7. Which sphere of sports is L.B. Rosa the award winning Sri Lankan sportsman known for?
(1) Badminton (2) Football (3) Athletics (4) Boxing (.....)
8. What is the Government Department that does not belong to any Ministry in Sri Lanka?
(1) Customs Department (2) Auditor General Department
(3) Police Department (4) Immigration and Emigration Department (.....)
9. What is the lowest age limit set for employing children in domestic labour?
(1) 12 years (2) 13 years (3) 14 years (4) 15 years (.....)
10. Which of the following is a false statement regarding the current population in Sri Lanka, according to the reports of the 2012 Census and Statistics Department?
(1) Total population is 20 277 597.
(2) Female life expectancy is 79.59 years.
(3) Male life expectancy is 72.43 years.
(4) The density of the population is 450 per square kilometre. (.....)
11. Which is the incompatible pair?
(1) Devar Suryasena - Music (2) Father Peter Pillai - Education
(3) M.C. Siddi Lebbe - Commerce (4) D.B. Dhanapala- Journalism (.....)
12. The Registration of births and deaths in Sri Lanka was introduced by the
(1) Arabs. (2) Portuguese.
(3) Dutch. (4) British. (.....)
13. Which is the South American Country where a native of the country has been appointed as the President?
(1) Bolivia (2) Uruguay (3) Columbia (4) Ecuador (.....)
14. What is the grain that can be kept for a long period of time without being spoilt?
(1) Gingili (2) Kurakkan (3) Meneri (4) Barley (.....)



15. Sri Lanka has attained a high position with regard to human development because of
(1) many natural resources. (2) the availability of infrastructure.
(3) the high level of state welfarism. (4) the high literacy rate. (.....)
16. Which one of the following countries has the longest coastal belt?
(1) Chile (2) Russia (3) India (4) Brazil (.....)
17. What is the currency unit used in China?
(1) Peso (2) Yen (3) Yuan (4) Baht (.....)
18. Who was appointed recently as the State Secretary of the United States of America?
(1) Hillary Clinton (2) John Mckayne
(3) John Kerry (4) Condoliza Rice (.....)
19. What is the number of bones in an adult human body?
(1) 201 (2) 206 (3) 208 (4) 215 (.....)
20. What is the nationality of Pope Benedict XVI who resigned from office recently?
(1) Italian (2) Polish (3) French (4) German (.....)
21. According to the Convention of Child Rights, "a child" is one who is under
(1) 15 years. (2) 16 years. (3) 17 years. (4) 18 years. (.....)
22. Which of the following Indian city is well known for information technology?
(1) Chennai (2) Bangalore (3) Mumbai (4) Trichy (.....)
23. The statement, 'Philosophers have interpreted the world. But the real task is to change the world' was made by
(1) Karl Marx (2) Rousseau
(3) Ma O Zedong (4) Mahatma Gandhi (.....)
24. In which country is the Tahir Square where many political clashes have taken place, situated?
(1) China (2) Greece
(3) Egypt (4) Myanmar (.....)
25. What is the biggest problem that the world has to face as a result of the Scientific and Technological Development?
(1) Depletion of resources (2) Manufacture of weapons
(3) Global warming (4) Conspicuous consumption (.....)
26. Which is the Asian country that is famous for human and physical resource management?
(1) China (2) Singapore
(3) Malaysia (4) Japan (.....)
27. 2012 DA 14 is
(1) a latest anti weapon-missile produced by America.
(2) a computer virus discovered recently.
(3) an astroid that travelled close to the earth recently.
(4) a space shuttle landed on Mars. (.....)



28. Which is the range of mountains that separates Asia from the European Continent?
(1) the Everest (2) the Urals (3) the Alps (4) the Pyranees (.....)
29. In which of the dramas of William Shakespear is the character of Brutus found?
(1) Merchant of Venice (2) Julius Caesar
(3) Romeo and Juliet (4) Hamlet (.....)
30. Which is the primary chemical found in limestone?
(1) Clacium Oxide (2) Calcium Sulphate
(3) Calcium Carbonate (4) Calcium Phosphate (.....)

● For each of the questions from No. 31 to 50, write the answer on the dotted line provided.

31. What is the term used to convey the present language policy of Sri Lanka?

.....

32. State the code route number of the first Highway in Sri Lanka.

.....

33. What is the name of the Power Plant that was recently constructed to provide electricity to the Jaffna Peninsula?

.....

34. Who is the Sri Lankan Judge who has served as the Vice President of the International Court of Justice?

.....

35. What is the highest honorary title awarded for national service in Sri Lanka?

.....

36. What is the Asian Country which has been isolated by most International Organizations of the World?

.....

37. How is an order given by a higher court to a lower court instructing it to render its general duties known?

.....

38. What is the Indian religious festival held once in 12 years to which the highest number of pilgrims of the world is drawn?

.....

39. Which UN Agency is considered as the clearing house for Education in the World?

.....



40. Which country is planning to hold a referendum to sever itself from Great Britain?

.....

41. What is the sport, Serena Williams is famous for?

.....

42. What is the name of the Pakistan girl who was shot by a Taleban militant in 2012, for raising her voice for women's right to education?

.....

43. Why have laws on mixing iodine to salt been enforced?

.....

44. Write the full name of the international organization, indicated by the acronym 'ASEAN'.

.....

45. Who is the inventor of the computer language known as 'Java'?

.....

46. What is the name given to the technology which enables you to join the computer network without cords/lines?

.....

47. What is the reason for the film 'Vishvarupam' by Kamal Hassan, to be suspended temporarily in Tamilnadu as well as in Sri Lanka?

.....

48. Who is the distinguished Indian Sitar maestro who died recently?

.....

49. Which Court of Justice issues a writ of Habeas Corpus?

.....

50. Who was the British planter who worked together with the leftist parties of Sri Lanka to uplift the living conditions of the estate labourers during the period when Sri Lanka was a Colony?

.....

* * *



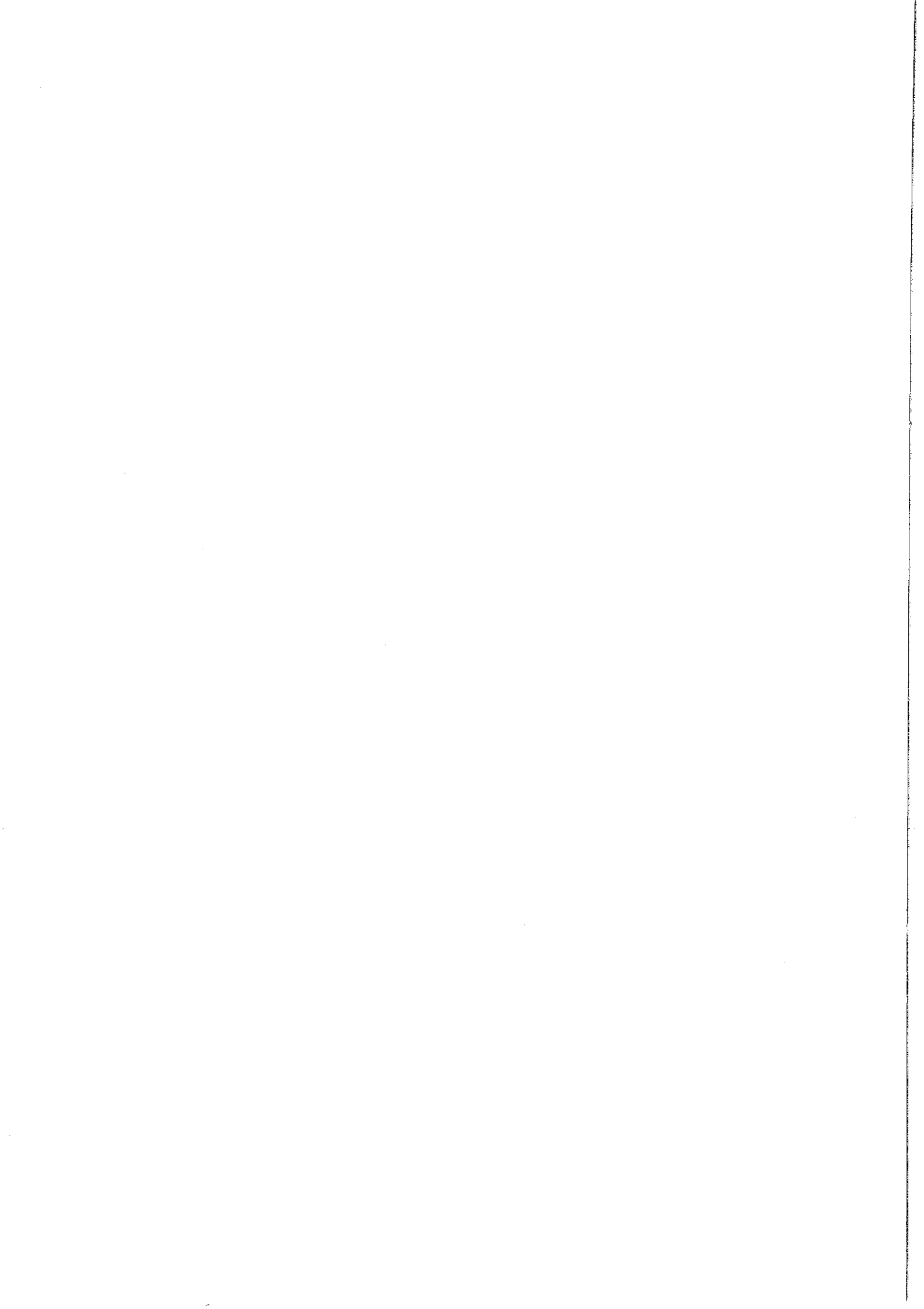

ශ්‍රී ලංකා විභාග දෙපාර්තමේන්තුව / இலங்கைப் பரீட்சைத் திணைக்களம் / Department of Examinations, Sri Lanka

Sri Lanka Law College Entrance Examination - Model Paper

(02) General Knowledge and Intelligence
 Part II - Intelligence

One hour

Instructions to Candidates

Very Important :

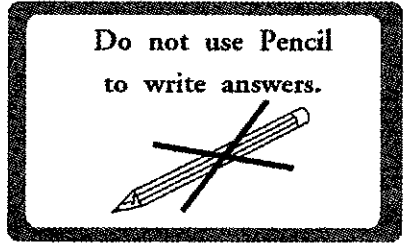

* Answer scripts where the numbers are not written as indicated below will not be marked / evaluated.
1 2 3 4

Write your Index Number here and on page 3 in the space indicated.

.....

Checked as correct

.....

Invigilator's Initials

Important :

- * This paper consists of 50 questions on 08 pages.
- * Answer all questions on this paper itself.
- * The time allowed for this paper is one hour.
- * Commence answering only after the Centre Supervisor's announcement.
- * Instructions given should be strictly followed in answering this paper and marks will not be awarded for answers not in accordance with these instructions.
- * Calculators should not be used.
- * Even if you are not attempting the paper hand it over to the Supervisor.
- * Write the answers clearly and legibly in blue or black ink only and not in pencil.
- * It is an offence to remove this paper from the examination hall or turn out photocopies of the same.
- * Answer scripts with illegible figures, illegible handwriting, those where erasing fluid has been used and written in pencil will not be marked / evaluated.

For Examiner's use only

Page No.	Question Nos.	Marks awarded
2	1 - 11	
3	12 - 20	
4	21 - 25	
5	26 - 31	
6	32 - 35	
7	36 - 45	
8	46 - 50	
Total		

Final Score

In figures	
In words	

Marking Examiner	
Checked by	

● Under each of the questions from No. 1 to 5, four pairs of words each are given. Of them, three pairs of words show a certain relationship among the words contained in them. Select the pair of words that does **not** show such relationship and write the **number** of the choice relevant to it **on the dotted line** provided against the question.

1. (1) farm - harvest (2) hospital - treatment
(3) school - education (4) bank - loans (.....)
2. (1) elder brother - younger brother (2) mother - son
(3) grand father - grand son (4) aunt - niece (.....)
3. (1) fish - fins (2) parrot - feathers
(3) motor vehicle - tyres (4) boat - water (.....)
4. (1) elephant - deer (2) iguana - crocodile
(3) ship - boat (4) mattress - pillow (.....)
5. (1) patient - hospital (2) pupil - school
(3) offender - prison (4) destitute person - refugee camp (.....)

● Under each of the questions from No. 6 to 10, the three words given at first show a similar relationship according to a certain characteristic. Select another word that shows the same relationship out of the choices of answers and write the **number** of the choice relevant to it **on the dotted line** provided against the question.

6. aunt, father, mother
(1) elder brother (2) uncle (3) younger brother (4) grand father (.....)
7. mountain, plateau, river
(1) current (2) tank(wewa) (3) sea (4) precipice (.....)
8. handkerchief, sarong, frock
(1) belt (2) flag (3) hat (4) blouse (.....)
9. potato, sweet potato, carrot
(1) leeks (2) raddish (3) peanuts (4) ginger (.....)
10. lungs, heart, kidneys
(1) liver (2) brain (3) nose (4) mouth (.....)

● Under each question from No. 11 to 15, two statements I and II, and two conclusions A and B that are expected to be reached on the basis of those statements are given. Though, those statements or conclusions may seem to be false, they should be considered as true here.

Accordingly, based on the two statements given, out of those two conclusions

- * if only the conclusion A can be reached definitely, write number 1,
 - * if only the conclusion B can be reached definitely, write number 2,
 - * if both conclusions A and B can be reached definitely, write number 3,
 - * if both conclusions A and B cannot be reached definitely, write number 4,
- on the dotted line** provided against the question.

11. **Statement** : I. All story books are newspapers.
II. Some newspapers are magazines.
Conclusion : A. Some magazines are newspapers.
B. Some story books are magazines. (.....)



12. **Statement** : I. All clerks are managers.
II. All managers are teachers.
Conclusion : A. All managers are clerks.
B. All clerks are teachers. (.....)
13. **Statement** : I. All cricketers are volleyball players.
II. All elle players are cricketers.
Conclusion : A. There are no cricketers who do not play elle.
B. There are no cricketers who do not play volleyball. (.....)
14. **Statement** : I. Some pens are pencils.
II. All pencils are books.
Conclusion : A. Some pens are pencils as well as books.
B. Some pens are books. (.....)
15. **Statement** : I. Some butterflies are birds.
II. The butterflies that are not birds are geckos (house lizards).
Conclusion : A. There are butterflies that are neither birds nor geckos.
B. The birds that are not buterflies are not geckos. (.....)

● In each question from No. 16 to 20, a certain word each is coded according to a certain method and given at first. Select the answer that shows the second word given with that word too when it is coded in the same manner and write the **number** of the choice relevant to it **on the dotted line** against the question.

16. If the word CHAIR is coded and stated as RIAHC, as how is the word WHOLE stated when coded?
(1) EHOLW (2) HWOLE
(3) ELOHW (4) OLEWH (.....)
17. If the word LEVEL is coded and stated as OHYHO, as how is the word DID stated when coded?
(1) RPR (2) GLG
(3) HLH (4) MAM (.....)
18. If the word ELEPHANT is coded and stated as DMDQGBMU, as how is the word MOUSE stated when coded?
(1) LPTTD (2) LPTVD
(3) KPTTD (4) LPTVF (.....)
19. If the word BEAR is coded and stated as CGDV, how is the word HAT stated when coded?
(1) JCV (2) ICW
(3) IBU (4) KEX (.....)
20. If the word WHERE is coded and stated as SDANA, as how is the word NUT stated when coded?
(1) JQP (2) KRQ
(3) JRQ (4) KRP (.....)



● Questions from No. 21 to 25 are based on the following information about planning of a time table for a course on Law Education.

✦ When preparing a time table of an institution where a course on Law Education is conducted, it has been planned to teach six subjects in six periods of one hour each from 8.00 a.m. to 4.00 p.m. on Mondays as follows. In addition to that, a period is allotted for the discussion of students' problems too.

* The six subjects that have been planned to be taught are Constitutional Law, Family Law, Land Law, Agreements Law, Administrative Law and Commercial Law.

* Agreements Law should be taught between 11.00 a.m. and 12.00 noon.

* Constitutional Law and Family Law, and Land Law and Family Law should be taught in two adjacent periods.

* Agreements Law and Commercial Law are taught by the same lecturer and he does not stay in the institution for more than three hours.

* Commercial Law has been planned to be taught after Constitutional Law.

* The last period has not been selected for the discussion of students' problems.

* Time from 12.00 noon to 1.00 p.m. is allotted for lunch.

According to this information, select the correct answer for each of the following questions and write the number of the choice relevant to it on the dotted line provided against the question.

21. For what is the period between 1.00- 2.00 p.m. allotted?

(1) Administrative Law

(2) Commercial Law

(3) Land Law

(4) Discussion of students' problems

(.....)

22. For which subject is the period from 8.00 - 9.00 a.m. allotted?

(1) Constitutional Law or Family Law

(2) Constitutional Law or Land Law

(3) Family Law or Land Law

(4) Agreements Law or Commerce Law

(.....)

23. For which subject is the period from 9.00 -10.00 a.m. allotted?

(1) Constitutional Law

(2) Family Law

(3) Land Law

(4) Administrative Law

(.....)

24. For what is the period from 2.00 - 3.00 p.m. allotted?

(1) Discussion of Students' problems

(2) Commercial Law

(3) Administrative Law

(4) Constitutional Law

(.....)

25. To teach which subject is the period from 10.00 - 11.00 a.m. allotted?

(1) Constitutional Law or Administrative Law

(2) Constitutional Law or Land Law

(3) Family law or Land Law

(4) Constitutional Law or Commercial Law

(.....)



- Questions from No. 26 to 30 are based on the following diagram that represents a group of members of a certain society and the information related to it.

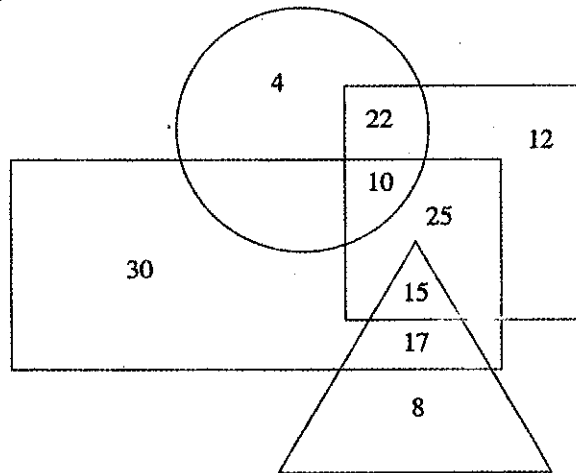

- * Here, the large rectangle represents the female members of the society.
- * The circle represents the members who are engaged in government employment.
- * The large triangle represents the members with more than 10 years membership.
- * The large square represents the married members.

According to this information, find the correct answer for each of the following questions and write that answer on the dotted line provided against the question.

- How many members though married are there who are **not** having over 10 years membership? (.....)
- Among this group how many married females are there who are **not** engaged in government employment? (.....)
- How many **unmarried** female members are there who are **not** engaged in government employment? (.....)
- What is the difference between the number of members who are engaged in government employment and that of married females? (.....)
- How many members do **not** belong to the married category? (.....)

- In each question from No. 31 to 35, four diagrams each arranged in a certain pattern are given with a mark "?". To suit that pattern, select the diagram that should be at the place marked with "?" and write the **number** of the choice relevant to it on the dotted line provided against the question.

31.

				(.....)
(1)	(2)	(3)	(4)	



32.

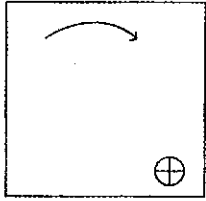
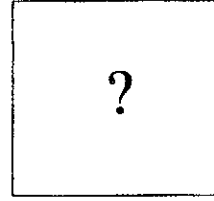
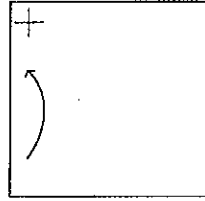
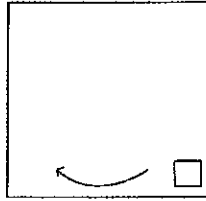
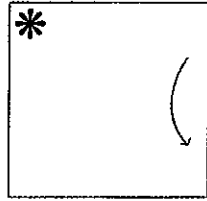
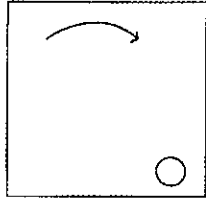

(1)

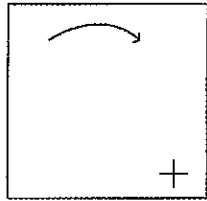

(2)

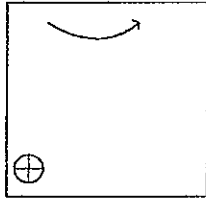

(3)

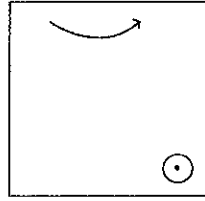

(4)

(.....)

33.

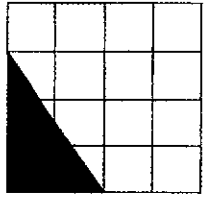
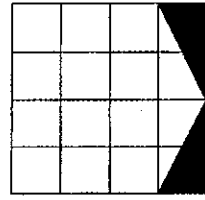
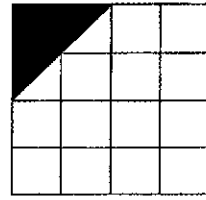
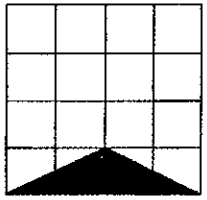
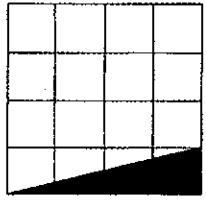

(1)

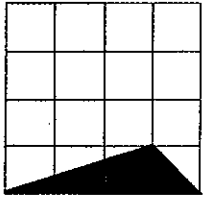

(2)

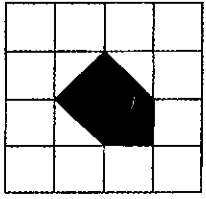

(3)

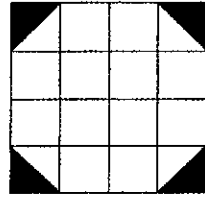

(4)

(.....)

34.

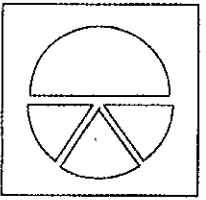
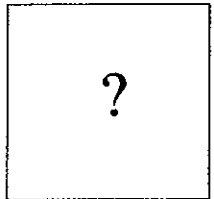
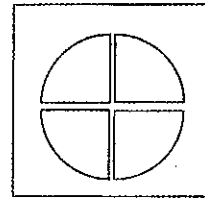
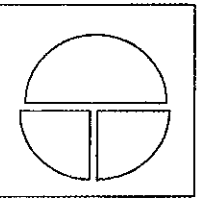
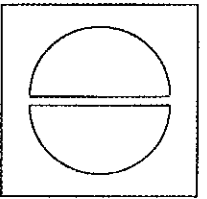
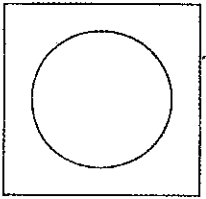

(1)

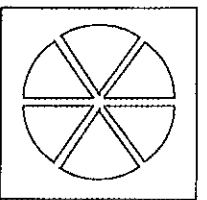

(2)

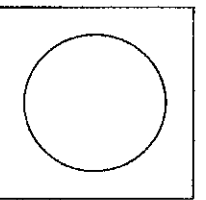

(3)

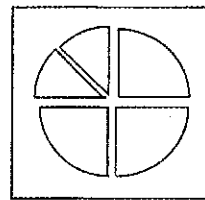

(4)

(.....)

35.

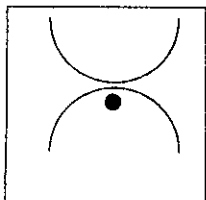
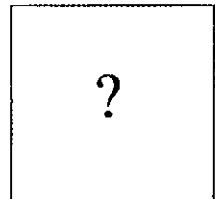
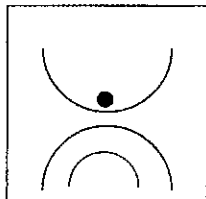
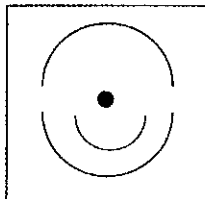
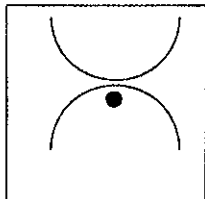
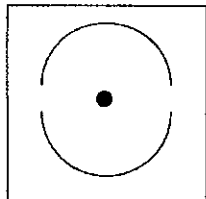

(1)

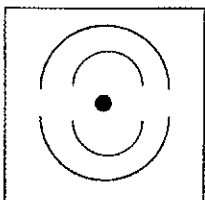

(2)

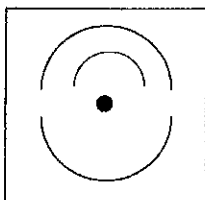

(3)

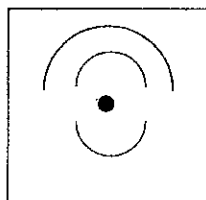

(4)

(.....)



● For each question from No. 36 to 40, select the correct answer and write that answer on the dotted line provided against the question.

36. A particular man walks 100 m to the east and then turns to the left and walks 50 m. Again he turns to the right, walks 100 m and turns to the right again and walks 50 m. How far is he now from the place where he started his journey in metres? (.....)
37. When Chaminda was born, his father was 30 years older than Chaminda's brother and his uncle was 20 years older than Chaminda's sister. Chaminda's uncle is 4 years younger than Chaminda's father. Chaminda's brother is 5 years older than Chaminda. When Chaminda was born how old was his sister, in years? (.....)
38. On a paper the letters A,B,C,D and E have been written in a line in order. A particular child counts the numerals upto 267 so as A=1, B=2, C=3, D=4, E=5 etc from left to right and again as D=6, C=7, B=8, A=9 etc from right to left and again as B=10, C=11 etc from left to right. Which letter does he count as 267? (.....)
39. Mr. Silva settled a loan taken from Mr. Mr. Perera in Rs. 10 notes and Rs. 50 notes. Mr. Perera counted the money and told that it was Rs. 200 less. The reason for that was, he had erroneously counted Rs. 10 notes as Rs. 50 notes and Rs. 50 notes as Rs 10 notes. If the total number of notes used for repaying the loan is 35, what is the loan to be paid by Mr. Silva? (.....)
40. A cat tries to reach the top of a post that is 40 feet high, along it. Until it reaches the top, it maintains the same speed. It climbs up 10 feet each of the post in every 2 minutes. Each time it climbs 10 feet, it slips down 4 feet. How many minutes does it take to reach the top of the post? (.....)

● For each question from No. 41 to 45, a grid of numerals each arranged in a certain pattern is given. According to the pattern find the numeral that should be posted at the place marked with "?" and write that numeral on the dotted line provided against the question.

41.

8	27	3
5	36	6
7	24	3
9	?	6

 (.....)
42.

8	40	13
7	14	9
10	40	14
5	?	12

 (.....)
43.

4	52	6
3	58	7
6	40	2
8	?	3

 (.....)
44.

4	23	5
8	45	7
2	24	5
6	?	9

 (.....)
45.

12	35	13
7	28	11
9	33	14
11	?	15

 (.....)



● Under each question from No. 46 to 50, four diagrams where numbers have been posted according to a certain common pattern are given. According to that pattern, find the numeral appropriate to be posted at the place marked with "?" and write that numeral on the dotted line provided against the question.

46.

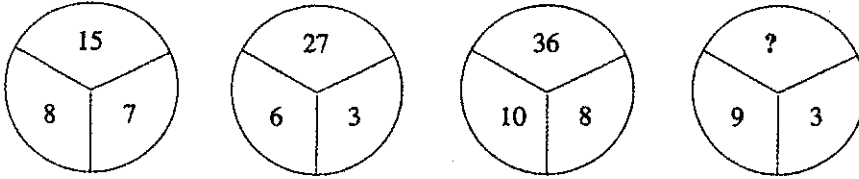

(.....)

47.

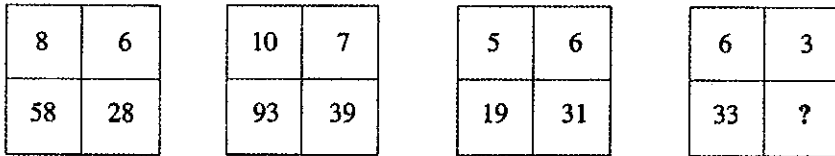

(.....)

48.

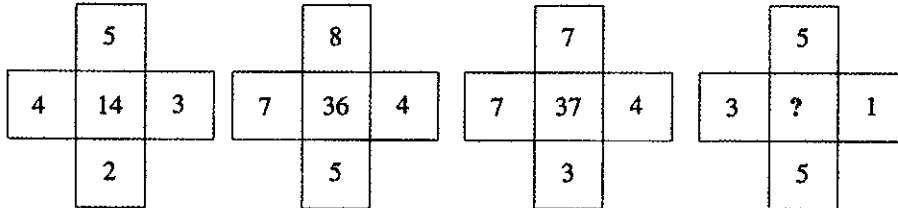

(.....)

49.

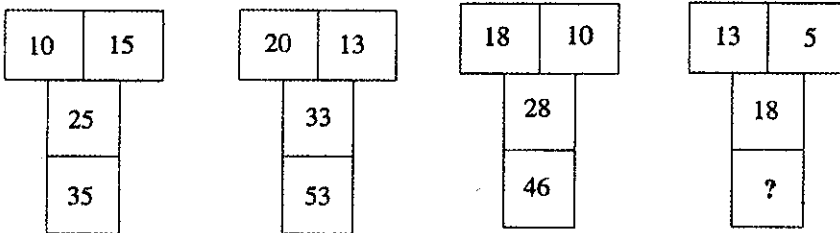

(.....)

50.

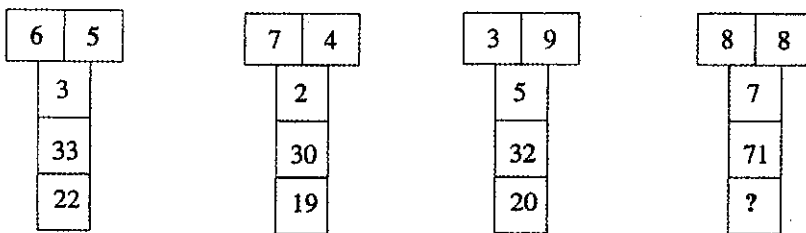

(.....)

